



UV-C DISINFECTION

- LCD SERIES -

80/2 LCD model

IT	ENG	FR	
Portata max	Max Flow rate	Débit max	12 m ³ /h
N. lampade UV-C	No. of UV-C lamps	Nombre de lampes UV-C	2
Durata lampade (ca.)	Life of lamps (around)	Durée des lampes (environ)	9.000 h
Dose UV-C	UV-C Dose	UV-C Dose	> 400 J/m ²

COLLETTORE	UV-CHAMBER	COLLECTEUR	
Materiale (Su richiesta)	Material (On request)	Matériel (Sur demande)	AISI 304 (AISI 316L)
Raccordi IN-OUT (*)	IN-OUT connections (*)	Raccords IN-OUT (*)	1 ½"
Scarico e sfiato	Drain and breather	Décharge et soupirail	½" - 1/8"
Pressione di lavoro (max.)	Working pressure (max.)	Pression de travail (max.)	9 bar

QUADRO ELETTRICO		ELECTRICAL PANEL	PANNEAU ELECTRIQUE		
80/2 LCD PLUS	80/2 LCD	Alimentazione elettrica	Electrical alimentation	Alimentation électrique	230 V – 50/60 Hz
		Consumo elettrico	Electrical absorption	Absorption électrique	160 Wh
		Grado protezione	Protection degree	Degré de protection	IP 55
		Cavo alimentazione	Feeding cable	Cable d'alimentation	100 cm
		Cavo collegamento	Connection cable	Cable de connexion	100 cm
		Display LCD (controllo a microprocessore)	LCD Display (microprocessor control)	Display LCD (microprocesseur controle)	●
		Contaore	Hour-meter	Compte-heures	●
		Led rosso di anomalia	Red led of anomaly	Led rouge D'anomalie	●
		Relè Allarme Contatto Pulito NA/NC	Alarm relay Free Contact NO / NC	Relay d'alarm Contât libre NA/NC	●
		Relè Allarme Uscita 230 V NA / NC – 2A max	Alarm relay 230 V NO / NC outlet – 2 A max	Relay d'alarm Sortie 230V NO / NC – 2A max	●
	Contaore resettabile con avviso fine vita lampada	Resettable count down hour-meter with alarm for end lamp life	Compte-heures resettable avec alarme de fin vie de la lampe	●	
	Display controllo irraggiamento/temperatura	Display of Irradiation /temperature control	Display pour contrôle irradiation et température	●	
	Spegnimento per alta temperatura collettore	Shutdown for high temperature UV chamber	Eteignement pour haute température collecteur	●	
Uscita 4 – 20 mA	4-20 mA Outlet	Sortie 4 – 20 mA	Optional		

Dosaggio calcolato con trasmittanza 99% a 1 cm, T=20°C, dopo 9000 h
 Dose calculated with transmittance 99% at 1 cm, T=20°C and after 9000 h
 Dosage calculé avec transmittance 99% à 1 cm, T=20°C et après 9000 h

(*) UNI EN ISO 228-1:2003

COMPANY WITH QUALITY MANAGEMENT
 SYSTEM CERTIFIED BY DNV
 = ISO 9001:2008 =

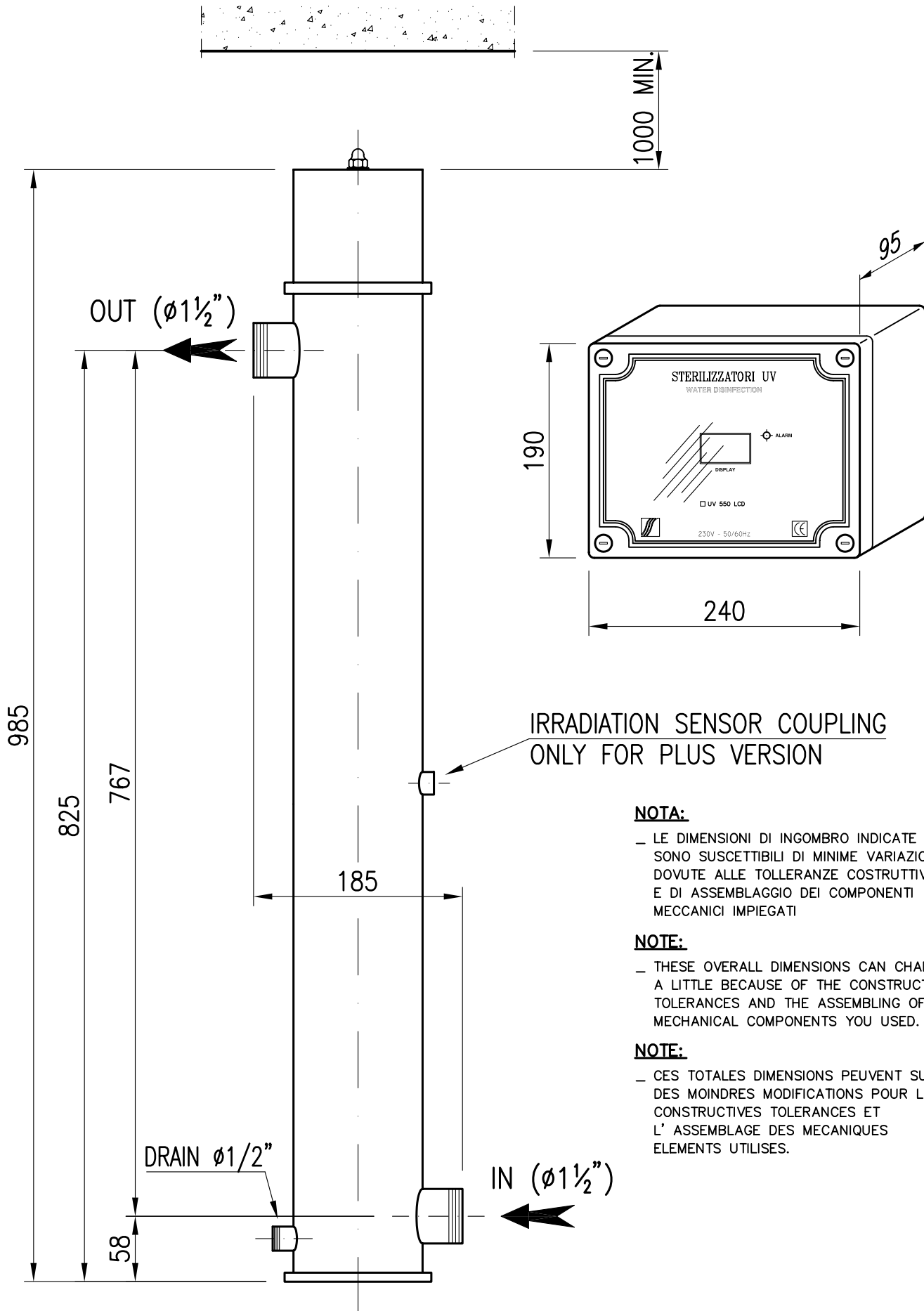

IRRADIATION SENSOR COUPLING
ONLY FOR PLUS VERSION

NOTA:

– LE DIMENSIONI DI INGOMBRO INDICATE SONO SUSCETTIBILI DI MINIME VARIAZIONI DOVUTE ALLE TOLLERANZE COSTRUTTIVE E DI ASSEMBLAGGIO DEI COMPONENTI MECCANICI IMPIEGATI

NOTE:

– THESE OVERALL DIMENSIONS CAN CHANGE A LITTLE BECAUSE OF THE CONSTRUCTIVE TOLERANCES AND THE ASSEMBLING OF MECHANICAL COMPONENTS YOU USED.

NOTE:

– CES TOTALES DIMENSIONS PEUVENT SUBIR DES MOINDRES MODIFICATIONS POUR LES CONSTRUCTIVES TOLERANCES ET L' ASSEMBLAGE DES MECANQUES ELEMENTS UTILISES.

					CODICE	TITOLO			
						UV-C DISINFECTION			
						UV 80/2 LCD MODEL			
						LAY-OUT			
A	FIRST ISSUE	07/12/11	SCHENONE	MAZZONE	Disegnato		UFFICIO TECNICO	Foglio	01
REVISIONE	DESCRIZIONE	DATA	DISEGNATO	VERIFICATO	Data		07/12/11	Segue	/
Via Rivarolo, 61 - 16161 Genova Italy - Tel. 0039-10-7406848 / Fax 0039-10-7406851 email info@sitaouv.com					Scala		/	Totale Fg.	01



S.r.l. Società Italiana Trattamento Acque

Via Rivarolo, 61 - 16161 Genova Italy - Tel. 0039-10-7406848 / Fax 0039-10-7406851 email info@sitaouv.com